

## Operating Manual and Test Log

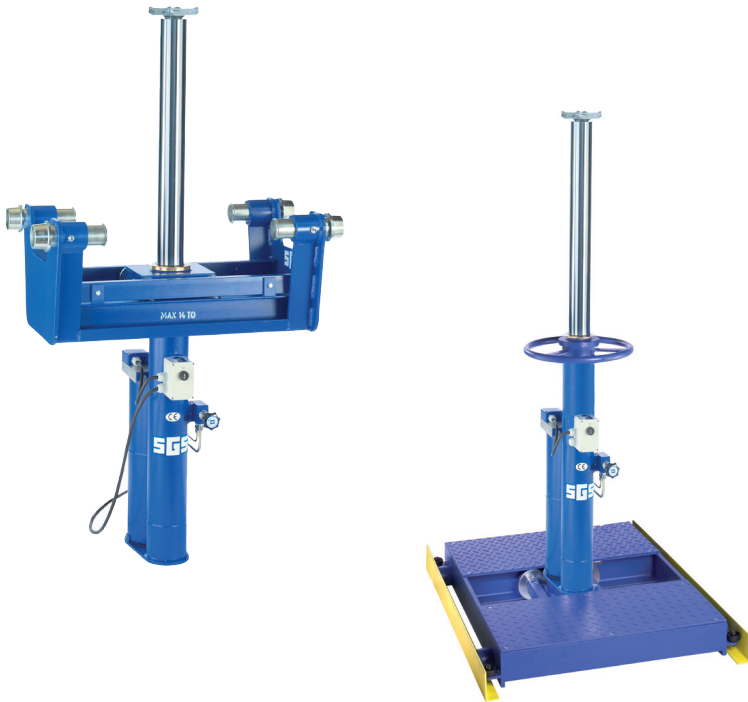

**Pit lift  
HKE / FKE  
Lifting capacity 10 t, 14 t, 20 t**

**SOMMERER PIT LIFT**

## Important:

- Release hand brake so that the vehicle can roll.
- ▶ **When working under lifts with drive-on rails, always observe the shift in center of gravity when lifting axles or body parts. When the counterweight of the axle is not on the rail, the lifting platform can become overloaded or the stability can be reduced.**
- Disconnect the lift from the power supply at night.

## Notes:

<b>Content</b>	<b>page</b>
Data Sheet	4
Test Log	5
<b>1. SAFETY REGULATIONS</b>	<b>6</b>
1.1. Introduction	6
1.2. Application areas of the SOMMERER pit lifts	6
1.3. Notes for compliance with the operation manual	6
1.4. Operation of the site operator	7
1.5. Hazards handling the pit lifts	7
1.6. Organisational methods	8
1.7. Maintenance tasks, fault clearance, disposal	9
1.8. Specific hazards	9
1.9. Safety regulations	10
<b>2. DESCRIPTION</b>	<b>11</b>
2.1. Utilization and application	11
2.2. Description of design and functions	11
2.3. Transport	12
<b>3. INSTALLATION</b>	<b>12</b>
3.1. General	12
3.2. Setup and installation location HKE	12
3.3. Bleeding	13
3.4. Setup and installation location FKE	14
3.5. Electrical connection	14
<b>4. OPERATION</b>	<b>15</b>
4.1. Lifting loads	16
4.2. Lowering loads	16
4.3. Load bearing devices and support bridges	17
4.4. Instructions for use	17
<b>5. MAINTENANCE</b>	<b>18</b>
5.1. Special instructions	18
5.2. Maintenance	18
5.3. Oil level check	19
<b>6. MALFUNCTIONS</b>	<b>19</b>
6.1. General	18
6.2. Troubleshooting	20
6.3. Replacement equipment and repair	20
<b>7. WARRANTY</b>	<b>21</b>
<b>8. ELECTRICAL- AND HYDRAULIC DIAGRAM</b>	<b>22</b>
8.1. Electrical Diagram HKE/FKE 400 V (Standard)	22
8.2. Electrical Diagram HKE/FKE 240 V	23
8.3. Pit lift control	23
<b>9. HYDRAULIC DIAGRAM HKE/FKE</b>	<b>24</b>
<b>10. REPLACEMENT PARTS LIST</b>	<b>25</b>
<b>11. EC-DECLARATION OF CONFORMITY</b>	<b>26</b>

## Data Sheet

<b>Pit lift model:</b>				
<b>Lifting capacity:</b>				
<b>Year of manufacture:</b>				
<b>Factory no.:</b>				
	HKE/FKE	HKE/FKE	HKE/FKE	HKE/FKE
Lifting capacity	10 t	14 t	16 t	20 t
Max.hydr. operating pressure	160 bar	220 bar	205 bar	255 bar
Electrical connection 3 kW, 16 A	400 V	400 V	400 V	400 V
Lowering speed: max. 0,15 m/s				
Stroke: 800 mm				
Controller: electrohydraulic				
<b>Commissioning log:</b>				
The lift was installed and commissioned in accordance with the instructions on _____				
_____		_____		
Place/Date		Expert		
Name of expert		Address		
Deficiencies noted		Date / Site operator		
Deficiencies corrected		Date / Signature		



# 1. Safety regulations

## 1.1. Introduction

SOMMERER pit lifts are a result of many years of experience. The high quality standard and the superior design guarantee reliability, long service life and efficient operation. You should read this operating manual attentively and always observe the contents to prevent unnecessary damage and hazards. This operating manual is applicable both for rail-mounted pit lifts as well as for freely movable lifts.

## 1.2. Application areas of the SOMMERER pit lifts

**SOMMERER pit lifts are only permitted to be used for partial lifting of vehicles with support afterwards and/or for lifting and lowering vehicle parts (e.g. engines, gearboxes etc.). In doing so, the load must not exceed the maximum permitted load capacity of the pit lift.**

**Important: Any other or use beyond the described purpose is deemed as unintended use.**

ERICH SOMMERER GMBH shall not be liable for damage arising from this. The risk for this shall be borne solely by the user. Intended use also includes:

- compliance with all instructions in this operating manual
- compliance with the inspection and servicing work and the specified tests.

## 1.3. Notes for compliance with the operating manual

- The basic requirement for safe handling and trouble-free operation of the pit lift is the knowledge of the basic safety instructions and safety regulations.
- The operating manual must be observed by all persons who work on the pit lift. This particularly applies for Chapter 1.8 Specific Hazards.
- The applicable rules and regulations for the operating site must be observed in addition to the safety instructions in the operating manual.

#### 1.4. Obligation of the site operator

The site operator is obliged to only allow persons to work on the system who

- are familiar with the basic regulations for occupational health and safety and accident prevention and who have been instructed about handling the system.
- have read and understood the safety chapter and warnings and have confirmed this with their signature.

#### 1.5. Hazards handling the pit lift

The SOMMERER pit lifts have been designed and constructed according to the state of the art and the recognised safety regulations. Nevertheless, unintended use may endanger life and limb of the operator or damage property. The pit lift is only permitted to be used:

- for the intended use
  - in safe, faultless condition
- **Faults which can adversely affect safety must be rectified immediately.**
- Only put the pit lift in motion if there are no persons in the danger area.
  - The movement range of the pit lift must be kept clear.
  - No persons are permitted to be present in the movement range of the pit lift.
  - The maximum permitted load capacity of the pit lift must not be exceeded.
  - Climbing on the pit lift, riding on it and climbing on the load are forbidden!
  - Only load lift centrally, lift vehicle and check the safe vehicle support; do not lift to the required height until then
  - Secure the vehicle against rolling away.

- Make the lifting and lowering movements evenly. Monitor the load during the movement.
- **Pit lifts and transmission lifts are not suitable for holding loads over an extended period. Therefore, the raised load must be secured using support bridges or support blocks.**

## 1.6. Organisational measures

- The operating manual must always be kept ready to hand at the operating site of the pit lift.
  - In addition to the operating instructions, observe and enforce the generally applicable statutory and other binding regulations concerning accident prevention and environmental protection.
  - Check at least occasionally the safety and risk-conscious work of the personnel and compliance with the operating instructions.
  - Use personal protective equipment if necessary or required by regulations.
  - Observe all safety instructions and danger warnings on the pit lift.
  - All safety instructions and danger warnings on the pit lift must be maintained in legible condition.
  - Do not make any changes, attachments to and modifications of the pit lift which could affect safety without the permission of the manufacturer. This particularly applies for welding on load-bearing parts.
  - Spare parts must comply with the technical requirements specified by the manufacturer. This is only guaranteed for original parts.
  - Comply with legal deadlines or those specified in the operating manual for recurring tests / inspections.
- **In the event of malfunctions, shut down the pit lift immediately and secure against restarting. Have faults rectified immediately.**



## 1.7. Maintenance tasks, fault clearance, disposal

- Comply with the adjustment and maintenance work, inspections and dates including information about the replacement of parts/individual components specified in the operating manual. These activities must only be performed by qualified personnel.
- Always tighten screw connections which have been undone or loosened during maintenance and repair work.
- Arrange safe and environmentally sound disposal of operating and auxiliary materials (hydraulic oil) and exchange parts.

## 1.8. Specific hazards

### Hydraulics, pneumatics

- Work on hydraulic equipment must only be performed by persons with knowledge and experience of hydraulics.
  - Check all lines, hoses and screw connections regularly for leaks and externally recognisable damage. Rectify any damage immediately. Squirting oil can result in injuries and fire.
  - Depressurise pressure lines to be opened (hydraulics, compressed air) before starting repair work.
- **Lay and mount hydraulic and compressed air lines properly. Do not mix up connections. Fittings, length and quality of the hose lines must comply with the requirements.**

### Oils, grease and other chemical substances

Observe the applicable safety regulations for the product when handling oils, greases and other chemical substances.

## 1.9. Safety regulations

### Applied safety regulations

**The following standards were implemented in the design:**

- The safety devices comply with EN1494:2009-5
- The lift complies with the safety regulations of the following directives: 2006/42 EC Machinery Directive..
- The CE Declaration of Conformity is part of this operating manual.

**Observe the following during operation:**

- The accident prevention regulations of your country apply
- 89/391/EEC Safety and health protection of employees
- 89/654/EEC Safety and health protection in work facilities.
- 89/655/EEC Safety and health protection when using work equipment
- 89/656/EEC Safety and health protection when using personal protective equipment
- 92/58/EEC Safety and/or health labeling in the workplace

### Applied safety standards

- EN ISO 12100-1:2003/ DIN EN 294/ prEN 349/ EN 414/ EN 418/ prEN 811 / EN 50099/ EN 60204 / ISO 1219/ ISO/DIS 11530
- ▶ **EU-Directives are available: DITR German Information Centre for Technical Regulations in DIN e.V., Berlin**

## 2. Description

### 2.1. Utilization and application

The pit lift is designed exclusively for the vertical lifting of motor vehicles over assembly pits, with a max. axle load corresponding to the max. lifting capacity of the lift.

The lift must be commissioned by a competent and trained person. The design of the lift may not be modified in any way.

The load raised using the lift must be supported using suitable support systems. ERICH SOMMERER GmbH also provides these support systems.

- ▶ **For FKE-FV: When working under lifts with drive-on rails, always observe the shift in center of gravity when lifting axles or body parts. When the counterweight of the axle is not on the rail, the lifting platform can become overloaded or the stability can be reduced.**
- ▶ **Always comply with the detailed operating and maintenance instructions.**

### 2.2. Description of design and functions

These electrohydraulic pit lifts are designed for lifting motor vehicles above assembly pits. The pit lift can be moved lengthways and crossways in the pit.

The pit lift HKE consists essentially of a supporting plate with axles and running rollers. The lifting cylinder is welded to the midpoint of the supporting plate. A base plate is welded underneath the lifting cylinder. At FKE, the base plate is connected to the chassis. The control is performed using an UP push button installed on the lift and an UP-DOWN button lowering valve.

The piston rod and guide are built into the lifting cylinder. At the top, the piston rod has a hole drilled to take holding devices. An attached support plate serves as the load bearing device. Other suitable supports can be attached for special load application points on vehicles (see accessories).

The hydraulic aggregate is located at the rear of the cylinder. For vehicles that have to be lifted at two points, attachable cross members must be used (see accessories: axle cross beams, support systems).

### 2.3. Transport

The pit lift can be transported standing or lying. The oil filling nozzle with integrated oil dipstick is replaced during transport by a tightly sealing stopper. This stopper must be replaced by the oil filling nozzle before commissioning

## 3. Installation

### 3.1. General

I

The pit lift should be installed by the manufacturer's or the sales company's trained installers. If the site operator has sufficiently trained installers (experts), the pit lift can also be installed by them. The correct installation and commissioning must be inspected by an expert and confirmed in the commissioning log on page 4.

### 3.2. Setup and installation location HKE

#### Adjustable chassis:

- The chassis is suited for a spacing of 860 to 1,000 mm between the running rails.
- The up to 14,5 t adjustable roller axles must be set so that the distance between the roller collar and the running rails is no more than 10 mm.
- Push the chassis once along the entire length of the pit to ensure this.
- The distance from the roller collar to the pit running rail must not exceed 10 mm at any point!
- In this position, the M10 safety bolts must be drilled. To do this, first tighten the bolts so that the tip of the bolt presses into the axle.
- Then drill the axle with an 8 mm drill bit. Secure the safety bolts with lock nuts after tightening.

### **Welded chassis (from 16 t or on request):**

- The chassis was manufactured according to your pit size; the roller collar must make contact with the running rail.
- Here again, the maximum distance between the roller collar and the running rail must not exceed 10 mm.

### **► In general, the following applies to both the adjustable and the welded chassis**

- The standard running rollers are authorized only for flat to slightly conical contact; they may need to be adapted by re-turning to more tilted running rails. For an extra charge we will provide the corresponding rollers (sketch required!).
- **It is not permitted to extend the rollers to compensate for misalignment.**
- It may be necessary to straighten the pit by welding in compensating profiles. Protruding concrete, interfering piping or wiring, etc. must be removed.
- Suspend the lift in the chassis; mount the locking bracket according to the instructions.

### **3.3. Bleeding**

- If the lift (hydraulic unit) has drawn in air due to oil level too low, oil must be filled in the head plate at the oil nozzle when the piston rod is **lowered**.
- Extend lift completely and fill 0.1 l of hydraulic oil at the unit.
- Open the bleed screw on the right of the head plate by 3 turns,
- Move lift completely to the top (against stop) and keep running until only oil still discharges.
- Close bleed screw.
- Lower lift completely; if necessary press piston rod completely to the bottom by hand. In doing so, excess oil may discharge at the unit.

- Check oil level monitoring on the lift. Repeat the procedure if necessary.

### 3.4. Setup and installation location for FKE

Depending on the model, the pit lift is guided on the pit floor in or on running rails, or it is freely movable on the floor of the pit.

#### **Chassis model Z**

Model Z has a chassis that runs on the floor in U-profiles, L-profiles or a flat steel plate installed at the site (preferably U100). The profiles must be aligned exactly parallel, to within 10 mm. To install the rollers, open the U-profile at a suitable location.

The pit lift is also freely movable crosswise in the chassis.

- ▶ **Important! Before inserting the chassis and lift in the U-profile, they must be secured so that they cannot move.**

#### **Chassis model F**

The F model has a chassis which runs along the floor, similar to the Z model. A flat steel plate can be used for the running surface. The rollers of the lift then run on the flat steel. This chassis can be guided laterally in the pit by means of adjustable spacer rollers.

#### **Chassis model FV**

The chassis of this lift is freely movable up to 1,000 kg on steering rollers. Loads exceeding 1,000 kg push down on the springs, so that the frame is on the floor. The lift is bolted solidly to the midpoint. The running rollers of the lift then run directly on the floor of the pit. The floor must be suitable for this purpose, i.e. level, solid and clean.

#### **Chassis model FV-Q**

A chassis model FV. In addition the lift can also be moved crossways on its chassis. Under normal conditions, the lift is completely stable. Since the chassis is not secured on the floor against tipping, you should be aware of the resulting dangers. Extreme side loading on a lift that can be moved laterally can result in additional tipping moments. Therefore, side loading should always be avoided.

### 3.5. Electrical connection

The pit lift may be connected only to a 3-phase 400 V supply with 3x16 A fuses. After connection, run the motor just briefly. If the pump does not supply oil (the piston rod does not extend), then 2 phases must

be swapped with each other. If a connection cable, other than the one which is supplied, is used for the lift, it is essential to use an H07RNF cast rubber cable.

Check supply line for damage and replace immediately if necessary.

The lift is also available for 240 V mains power. Special circuit diagrams must be observed here. Cables with large cross section are required.

## 4. Operation

The respective applicable accident prevention regulations must be complied with.

- The pit lift is only permitted to be operated by trained personnel.
- Only put the pit lift in motion if there is no danger to persons.
- The movement range of the pit lift must be kept clear and no persons are permitted to be in the movement range.
- The maximum permitted load capacity of the pit lift must not be exceeded.
- Climbing on the pit lift, riding on it and climbing on the load are forbidden.
- Only load lift centrally, lift vehicle and check the safe vehicle support; do not lift to the required height until then.
- Ensure that load is centered! Hold non-centered loads with cross members (2-point support).
- The load bearing device must be centred on the load. Watch out for the shift in centre of gravity during lifting.
- Make the lifting and lowering movements evenly. Monitor the load during the movement.
- The raised load must be supported with support bridges or support blocks.
- Engines must be secured reliably against slipping, sliding and tilting

on the load bearing device.

- Moving the lift under load is only permitted if special safety measures are observed.
- Attached equipment (e.g. gearbox plates) for engine and gearbox installation and removal must not be pivoted or tilted so that the structural stability is reduced. This means: all loads to be lifted are centered and evenly distributed.

#### 4.1. Lifting loads

- Before using the lift for a vehicle, release the hand brake and shift the transmission to neutral.
- Attach lifting gear at even, load-bearing points which are specified by the vehicle manufacturer.
- The load bearing device must be centered on the load. Watch out for the shift in centre of gravity during lifting.
- You must keep the movement area of the vehicle free, and keep the vehicle being moved under observation.
- It is forbidden for anyone to enter the area of movement.
- In the event of malfunctions, shut down the unit immediately and notify supervisor / service department.
- Always observe the applicable regulations EN 1494:2009-5/BGG 945/BGR 500
- To raise or lower, press the appropriate pushbutton or lowering valve

#### 4.2. Lowering loads

- ▶ **Make lowering movements slowly and evenly. Monitor the load during the movement.**
- Monitor the load during the movement.



- Remove rolling away protection (wheel chocks).
- Raise vehicle slightly and remove support bridges.
- Only open the threaded spindle a very little for lowering the load.
- The lowering speed is continuously controlled by turning the threaded spindle anticlockwise.
- Turn the threaded spindle as far as the stop for further lowering without load.

### **4.3. Load bearing devices and support bridges**

Various load bearing devices are available for lifting vehicles and vehicle parts. These include support plates, cross members, gearbox plates, special mountings and extensions.

Lifted vehicles must be secured with support bridges or support blocks. Support bridges are always manufactured to the pit dimensions. Their secure support must be guaranteed over the complete length of the pit.

### **4.4. Instructions for use**

The manual forces for starting the unloaded pit lift are at most 300 N, and the forces required to maintain the motion are max. 200 N. If these forces are exceeded, e.g. because of a rough runway, then a second person must assist.

- Never exceed the maximum permitted load capacity of the load bearing devices.
- Irrespective of the load bearing device, the load centre of gravity must always be precisely central above the pit lift.
- Only use load bearing devices with appropriate studs.
- Do not stack extension pieces.
- Transport of vehicles on the pit lift is not permitted when the lift is completely lowered and if the parts have been secured with straps or chains.

- Attach all load bearing devices directly to the piston rod.
- Do not use any stroke extension between lift and lifting gear (cross member, gear box plate etc.).
- The lifts are not suitable for use in car wash systems; if used there, they must be suitably covered and protected to prevent damage from the high humidity. The warranty does not cover rust! Residue from underbody sealing compounds will destroy the seals.
- Due to the corner load of the supporting plates, damage to the floor cannot be ruled out. Covering with tiles is only appropriate when the floor is very level.
- Under normal operating conditions, this universal lifting device is completely stable. Since the chassis is not secured against tipping on the floor, you should be aware of the possible dangers. Therefore, side loading should always be avoided.

## 5. MAINTENANCE

### 5.1. Special instructions

Original SOMMERER PIT LIFTS require minimal maintenance. It is important that the piston rod be kept clean. Damage must be immediately polished out with a gentle transition. When working with strongly adhering underbody compounds (underbody protection, wax etc.) the piston rod must be fully covered or - before lowering the lift - cleaned

Such compounds gum up the upper dirt and water wiper ring, which then no longer functions properly.

- ▶ **Do not clean pit lifts with high-pressure or steam cleaners, since cleaning agents can penetrate the valves and cause malfunctions.**

### 5.2. Maintenance

The piston rod, studs of the load carrying device, running rollers and other moving parts must always be lightly oiled.

Every time that it is retracted, the piston rod passes completely through the plunger system into the hydraulic oil, and is thereby automatically lubricated and protected against corrosion.

The hydraulic oil must be changed after no more than six years of operation. The initial fill at the factory is with BP HLP HM 35. A comparable oil can be used when changing the oil.

### 5.3. Oil level check

#### Important for oil level check

- ▶ **Disconnect the pit lift from the compressed air network!**
- ▶ **Check oil only when unit is not under pressure**
- ▶ **Check oil only when lift is not in motion.**
- ▶ **Ensure absolute cleanliness**
- ▶ **Use only filtered hydraulic oil**
- ▶ **Check oil level at least once per month.**

#### Bleeding

The pit lift is supplied filled with oil, and has been bled. If, after an extended period of operation or after an oil change, the piston rod extends jerkily, then the bleed screw underneath the head plate on the cylinder should be opened until oil escapes.

## 6. Malfunctions

### 6.1. General

- Quite often the problems that cause a malfunction are minor. Locating the cause of a malfunction is almost always the most time-consuming task in troubleshooting. As an automotive expert, you can carry out nearly all troubleshooting tasks yourself, in order to save money.
- Before shipping, every lift is subjected to several precise function tests under operating conditions with an excessive load. In addition, a seal check and completeness check are carried out.

However, if parts are missing at the time of delivery, or if malfunctions occur during commissioning, then in our daily experience the cause is in most cases beyond our control.

## 6.2. Troubleshooting

### a) Lift does not pump or will not hold a load

- Insufficient oil possibly lost during transport. Add low-viscosity hydraulic oil (HLP 35) as far as the upper mark on the dip stick. Ram must be fully in starting position!
- Check the non-return valve on the cylinder. Remove any dirt that may be present, or replace the valve.

If these first points are correct, then the groove ring in the guide must be defective. This generally does not occur until after at least four years. In this case, the lift must be overhauled.

Removal of the guide: Disconnect the pit lift from the power supply. Unscrew the guide using a suitable tool. The piston rod can remain in the lift. After installation, bleed the lift; see page 13.

### b) Oil loss on the piston rod

- Reseal the guide, replace the wiper ring and the groove ring

### c) Oil loss on the lifting or lowering spindle

- Replace seals; lubricate all sliding parts with Molykote.

## 6.3. Replacement equipment and repairs

Small repairs can be carried out by the customer, assuming technical competence. Replacement parts sets are available.

Please note the following when ordering replacement parts: In addition to the item number from the replacement parts list, you must specify the model and load capacity (from the data sheet), or alternatively the main dimensions of the piston rod, the lift height, and the year of manufacture.

In the event of major repairs, and after 4 to 5 years at the latest, the lift should undergo thorough maintenance and overhaul, for safety reasons.

We will repair your equipment within a few days, with a full factory warranty. Replacement equipment is available for common models and load capacities

## 7. WARRANTY

Our „General terms of sale and delivery“ are always applicable. These have been available to the customer since conclusion of the contract. Warranty and liability claims for personal injuries and damage to property are void if they are attributable to one or more of the following causes:

- Use of the pit lift for other than its intended purpose.
- Improper installation, commissioning, operating and maintenance of the pit lift.
- Operation with compressed air containing condensate and/or dirt. Operation of the pit lift with defective safety devices or with safety devices and protective equipment not properly installed or operational.
- Rust due to water in compressed air or from other influences such as salt in winter.
- Non-observance of the instructions in the operating manual concerning transport, storage, installation, commissioning, operation and maintenance of the pit lift.
- Unauthorised modification of the pit lift.
- Inadequate monitoring of parts which are subject to wear.
- Improperly performed repairs
- Disasters caused by external influence and force majeure.

In order for a warranty claim to be accepted, it is necessary that you describe the claim/defect to us in as much detail as possible. Prior to returning a shipment, please contact us by telephone first, since most claims turn out to be minor problems. We request that returns are made at the expense of the customer. After examination and acknowledgement of the claim, we will reimburse the freight costs incurred.

We cannot accept customer service requests and the costs for return arising from non-observance of the specified points. Therefore, before any return, contact the manufacturer.



## 8.2. Electrical diagram HKE /FKE 240 Volt (only on special request)

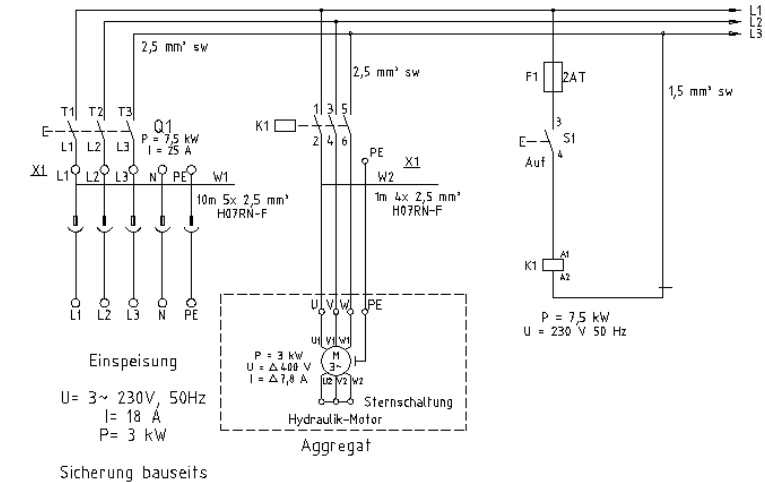

## 8.3. Lift control

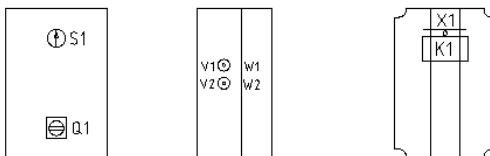

Verschleißteile

Q1 Hauptschalter

S1 Taste "Auf"

X1 Klemmleiste

K1 Luftschütz

		Gründentiefe h <sub>1</sub> in m (h <sub>2</sub> in m)						Nennschwerklast h <sub>1</sub> in kN							
Nennwert	Nennwert	h <sub>1</sub> < 5	h <sub>1</sub> < 7	h <sub>1</sub> < 9	h <sub>1</sub> < 11	h <sub>1</sub> < 13	h <sub>1</sub> < 15	h <sub>1</sub> < 17	h <sub>1</sub> < 19	h <sub>1</sub> < 21	h <sub>1</sub> < 23	h <sub>1</sub> < 25	h <sub>1</sub> < 27	h <sub>1</sub> < 29	h <sub>1</sub> < 31
		h <sub>2</sub> < 0,5	h <sub>2</sub> < 0,7	h <sub>2</sub> < 0,9	h <sub>2</sub> < 1,1	h <sub>2</sub> < 1,3	h <sub>2</sub> < 1,5	h <sub>2</sub> < 1,7	h <sub>2</sub> < 1,9	h <sub>2</sub> < 2,1	h <sub>2</sub> < 2,3	h <sub>2</sub> < 2,5	h <sub>2</sub> < 2,7	h <sub>2</sub> < 2,9	h <sub>2</sub> < 3,1
in mm <sup>2</sup>	in mm <sup>2</sup>	4x1	4x1	4x2	4x2	4x2	4x2	4x2	4x2	4x2	4x2	4x2	4x2	4x2	4x2

V1 bei 5 x 1,5 mm<sup>2</sup> = M20; bei 2,5 mm<sup>2</sup> = M25

V2 bei 4 x 1,5 mm<sup>2</sup> = M20; bei 2,5 mm<sup>2</sup> = M25

## 9. Hydraulic diagram HKE /FKE

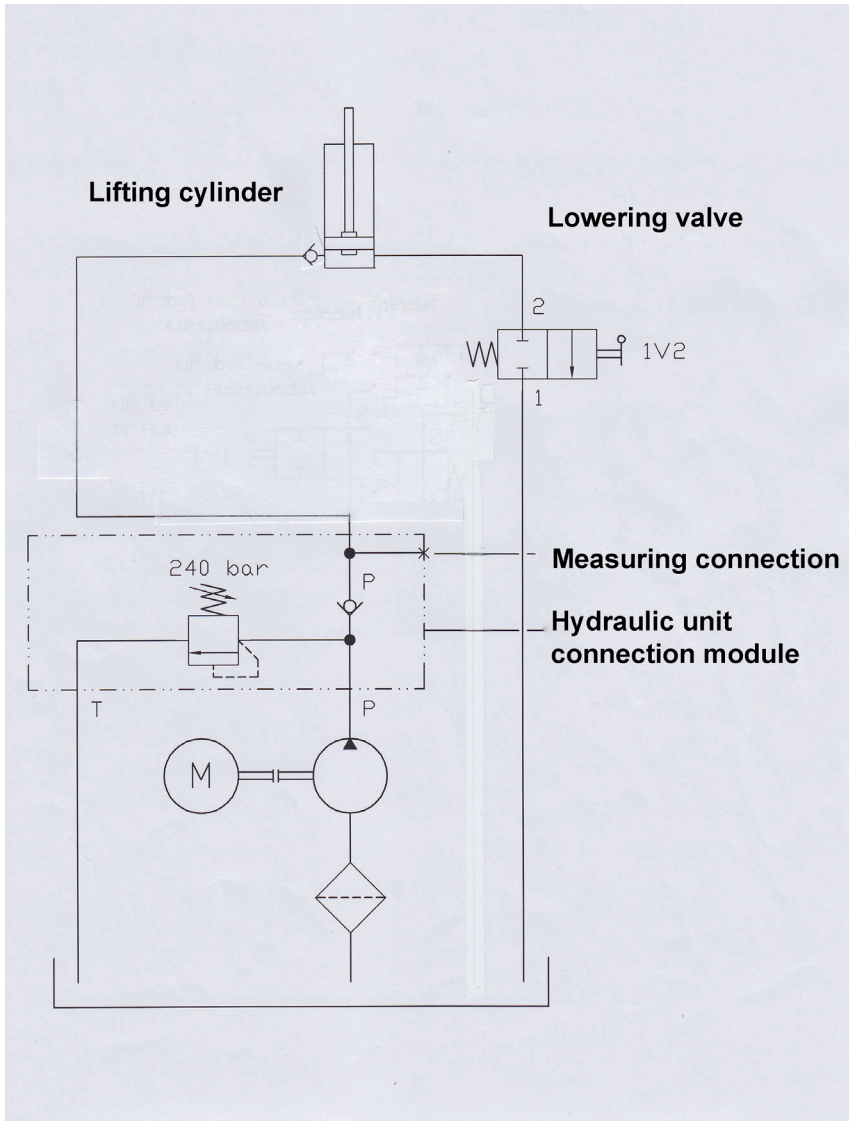



## 10. Replacement parts list

Position	Replacement part
200	Guide for piston rod
201	Sealing set for piston rod
202	Piston rod
203	End stop, complete, for piston rod
204	Lifting spindle with handwheel only for model with lifting spindle instead of pushbutton
205	Lowering spindle with handwheel
206	Sealing set for lifting and lowering spindles
207	Non-return valve, complete
208	End switch only for model with a lifting spindle
209	Cover for hydraulic block
210	Cover for hydraulic aggregate
211	Cover for hydraulic aggregate
212	Hydraulic hose 8 mm
213	Pushbutton „UP“
820	Claw
823	Lift roller, complete

**Manufacturer:**

**ERICH SOMMERER GMBH**  
Mönsheimer Straße 28  
D-71292 Friolzheim  
Telefon: + 49(0)7044/94 52-0  
Telefax: + 49(0)7044/94 52-31

hereby confirms that the following product:

<b>Designation:</b>	<b>Pit lift:</b>
<b>Model:</b>	<b>HKE / FKE</b>
<b>Year :</b>	<b>See data sheet in operating Manual/Test Log</b>
<b>Factory no.:</b>	<b>See data sheet in operating Manual/Test Log</b>

complies with the basic safety and occupational health requirements of the following EC directive

**EG- directive:**  
2006/42 EC for Machinery

**DIN EN-Standard:**  
DIN EN 1494:2009 5 „Mobile or movable jacks and associated lifting “

**Technical documentation:**

- Development and design documentation
- Hazard and risk analysis
- Certificate as per DIN EN ISO 9001: 2008
- Safety-compliant operating manual
- Assembly and installation instructions

Friolzheim, 30.05.2013

Signature:





---

## **Edition of the Operating Manual of May 2013**

Great care was taken in reviewing the information in this edition. Nevertheless, it is not possible to rule out errors altogether.

This operating manual is intended for users with previous technical knowledge in the field of automotive technology.

All rights reserved.  
Subject to modification of technical information and content.

### **ERICH SOMMERER GMBH**

Mönsheimer Straße 28  
D-71292 Frielzheim  
Telefon +49(0)7044/94 52-0  
Telefax +49(0)7044/94 52-31  
Email [info@sommerer.com](mailto:info@sommerer.com)  
[www.sommerer.com](http://www.sommerer.com)

